

AISI-304

**TIRADOR CORREDERA PASANTE Ø 40 mm**

1813

Vidrio 8/10 mm

**DOBLE**

Acabados:

|             |                  |
|-------------|------------------|
| Inox brillo | <b>1052.1 IB</b> |
| Inox mate   | <b>1052.1 IM</b> |

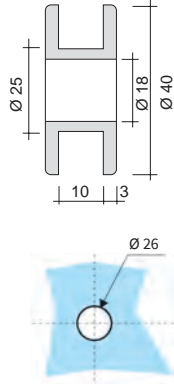

**TIRADOR CORREDERA PASANTE Ø 60 mm**

1812

Vidrio 8/10 mm

**DOBLE**

Acabados:

|             |                |
|-------------|----------------|
| Inox brillo | <b>1052 IB</b> |
| Inox mate   | <b>1052 IM</b> |

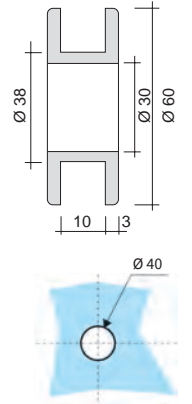

**TIRADOR CORREDERA CIEGO Ø 60 mm**

1819

Vidrio 8/10 mm

**DOBLE**

Acabados:

|             |                |
|-------------|----------------|
| Inox brillo | <b>1075 IB</b> |
| Inox mate   | <b>1075 IM</b> |

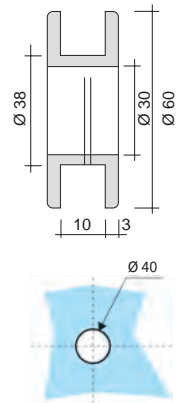

**TIRADOR CORREDERA MACIZO**

1824

Vidrio 8/10 mm

**DOBLE**

C.C. = 120 L = 180

Acabados:

|             |                |
|-------------|----------------|
| Inox brillo | <b>1054 IB</b> |
| Inox mate   | <b>1054 IM</b> |

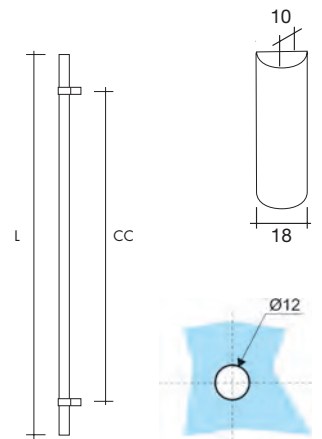

AISI-304

### TIRADOR CORREDERA Ø 60 mm

1814A

Para pegar  
Incluye adhesivo 3M VHB

**DOBLE**

**Acabados:**

|             |                   |
|-------------|-------------------|
| Inox brillo | <b>1053.20 IB</b> |
| Inox mate   | <b>1053.20 IM</b> |



### TIRADOR CORREDERA Ø 60 mm

1815A

Para pegar  
Incluye adhesivo 3M VHB

**DOBLE**

**Acabados:**

|             |                   |
|-------------|-------------------|
| Inox brillo | <b>1053.21 IB</b> |
| Inox mate   | <b>1053.21 IM</b> |
| Negro mate  | <b>1053.21 NE</b> |
| Blanco mate | <b>1053.21 BL</b> |



Negro mate

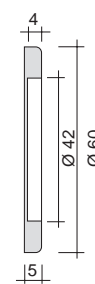

### TIRADOR CORREDERA 60 x 40 mm

1866A

Para pegar  
Incluye adhesivo 3M VHB

**DOBLE**

**Acabados:**

|             |                   |
|-------------|-------------------|
| Inox brillo | <b>1087.20 IB</b> |
| Inox mate   | <b>1087.20 IM</b> |

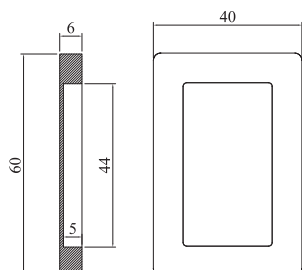

### TIRADOR CORREDERA 50 x 50 mm

1818A

Para pegar  
Incluye adhesivo 3M VHB

**DOBLE**

**Acabados:**

|             |                   |
|-------------|-------------------|
| Inox brillo | <b>1055.21 IB</b> |
| Inox mate   | <b>1055.21 IM</b> |

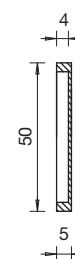

AISI 316

**TIRADOR DOBLE**

Para pegar

**L = 120**

Acabados:

|              |                          |                                      |
|--------------|--------------------------|--------------------------------------|
| Vidrio 8 mm  | Inox brillo<br>Inox mate | <b>1076 IB</b><br><b>1076 IM</b>     |
| Vidrio 10 mm | Inox brillo<br>Inox mate | <b>1076.1 IB</b><br><b>1076.1 IM</b> |
| Vidrio 12 mm | Inox brillo<br>Inox mate | <b>1076.2 IB</b><br><b>1076.2 IM</b> |

**L = 300**

Acabados:

|              |                          |                                      |
|--------------|--------------------------|--------------------------------------|
| Vidrio 8 mm  | Inox brillo<br>Inox mate | <b>1076.3 IB</b><br><b>1076.3 IM</b> |
| Vidrio 10 mm | Inox brillo<br>Inox mate | <b>1076.4 IB</b><br><b>1076.4 IM</b> |
| Vidrio 12 mm | Inox brillo<br>Inox mate | <b>1076.5 IB</b><br><b>1076.5 IM</b> |

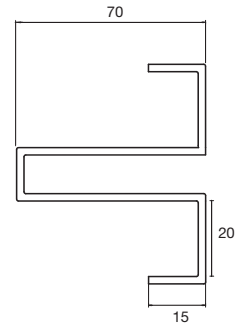

1844  
1843  
1845  
1847  
1846  
1848

**TIRADOR DOBLE**

Para pegar

**L = 120**

Acabados:

|              |                          |                                      |
|--------------|--------------------------|--------------------------------------|
| Vidrio 8 mm  | Inox brillo<br>Inox mate | <b>1058 IB</b><br><b>1058 IM</b>     |
| Vidrio 10 mm | Inox brillo<br>Inox mate | <b>1058.1 IB</b><br><b>1058.1 IM</b> |
| Vidrio 12 mm | Inox brillo<br>Inox mate | <b>1058.2 IB</b><br><b>1058.2 IM</b> |

**L = 2200**

Acabados:

|              |                          |                                      |
|--------------|--------------------------|--------------------------------------|
| Vidrio 10 mm | Inox brillo<br>Inox mate | <b>1058.6 IB</b><br><b>1058.6 IM</b> |
| Vidrio 12 mm | Inox brillo<br>Inox mate | <b>1058.7 IB</b><br><b>1076.7 IM</b> |

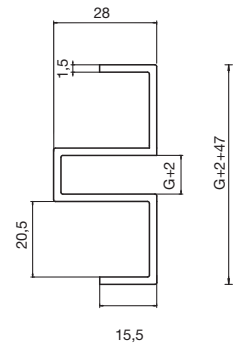

1830  
1829  
1831  
1833  
1832  
1834  
1835  
1836

**L = 400**

Acabados:

|              |                          |                                      |
|--------------|--------------------------|--------------------------------------|
| Vidrio 8 mm  | Inox brillo<br>Inox mate | <b>1058.3 IB</b><br><b>1058.3 IM</b> |
| Vidrio 10 mm | Inox brillo<br>Inox mate | <b>1058.4 IB</b><br><b>1058.4 IM</b> |
| Vidrio 12 mm | Inox brillo<br>Inox mate | <b>1058.5 IB</b><br><b>1058.5 IM</b> |

**TIRADOR SIMPLE**

Para pegar

**L = 120**

Acabados:

|              |                          |                                      |
|--------------|--------------------------|--------------------------------------|
| Vidrio 8 mm  | Inox brillo<br>Inox mate | <b>1057 IB</b><br><b>1057 IM</b>     |
| Vidrio 10 mm | Inox brillo<br>Inox mate | <b>1057.1 IB</b><br><b>1057.1 IM</b> |
| Vidrio 12 mm | Inox brillo<br>Inox mate | <b>1057.2 IB</b><br><b>1057.2 IM</b> |

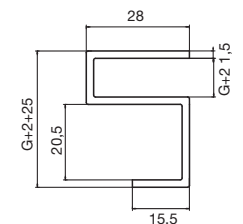

1827  
1826  
1828